

“service,
strength and
quality”

Multi-purpose Powered Sheave

THISTLE GROUP



This multi-purpose powered sheave is a robust, harsh environment bundled hose and rope sheave suitable for a variety of marine uses. Ideal for the over-boarding and retrieval of hose bundles, the powered sheave comes with an pivoting attachment bracket and an aluminium sheave with overlaid rubber to increase grip.

The sheave diameter, profile and bracket length can be sized to suit your hose handling and vessel requirements. Comes with hydraulic quick connects for easy connection / disconnection.



Technical Data (Based on 315mm Ø sheave)	
Maximum Line Pull:	1,000 kg
Maximum Working Speed	234 rpm
Working Line Speed:	0.2 to 3.8 m/s
Maximum Working Pressure:	450 bar
Maximum Oil Flow:	120 LPM
Total Weight:	120 kg

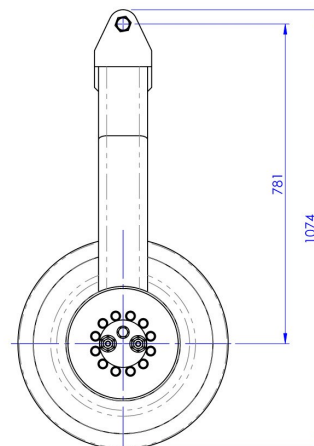
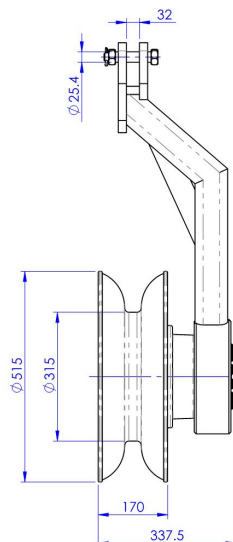

Key Points:

- Small footprint
- High line pulling power
- Lightweight
- Marine paint system
- Hydraulic quick connects



THISTLE GROUP HQ

5 Baltic Place, Peterhead,
Aberdeenshire, Scotland,
AB42 1TF

Tel: +44 (0)1779 477 210
sales@thistlemarine.co.uk
www.thistlegroup.co.uk