

“service,
strength and
quality”

Retractable Multi-purpose Hauler

THISTLE GROUP



The retractable multi-purpose hauler is a robust, harsh environment hose, rope and umbilical hauler suitable for a variety of marine uses. Ideal for the over-boarding and retrieval of hose bundles, the hauler features a pivoting arm to allow the hauler to be folded down when not in use. It also features a split base to allow it to be easily removed from the deck when not in use or to move it between vessels. The hauler sheave diameter, profile and bracket height can be altered to suit your hose handling and vessel requirements. Controlled either by side mounted control valves or via Thistle foot pedal controller.



Technical Data (Based on 300mm sheave)	
Maximum Line Pull:	950 kg
Maximum Line Speed:	2.8 m/s
Recommended Working Speed:	1—2 m/s
Maximum Working Pressure:	210 bar
Maximum Oil Flow:	60 LPM
Weight (including bracket):	160 kg

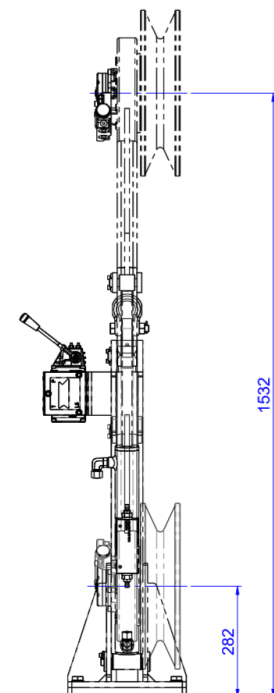
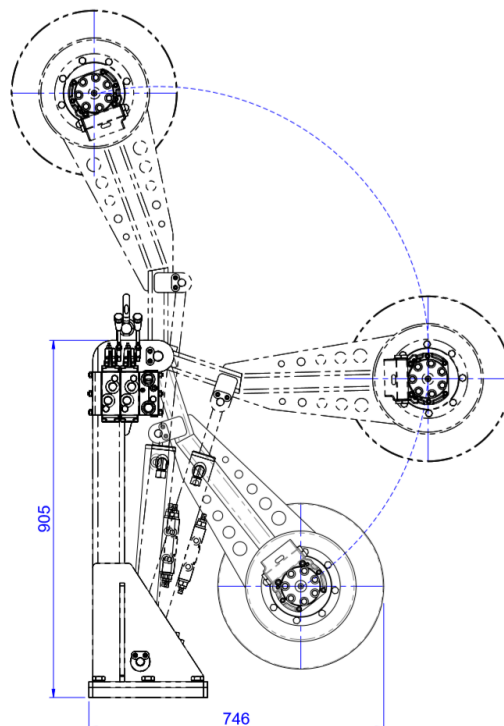

THISTLE GROUP HQ

5 Baltic Place, Peterhead,
Aberdeenshire, Scotland,
AB42 1TF

Tel: +44 (0)1779 477 210
sales@thistlemarine.co.uk
www.thistlegroup.co.uk