

“service,
strength and
quality”

THISTLE GROUP



HEILA MARINE CRANE
MODEL HLRM 70-4S
SERIAL NO: H9251

ASSET NUMBER TM0105

CRANE ON SKID



SPECIFICATION

SWL	6,750Kg
Reach	12.5mt
Weight	4,570Kg
Asset Number	TM0105
Year	unknown

SOLD AS SEEN



THISTLE GROUP HQ
5 Baltic Place, Peterhead,
Aberdeenshire, Scotland,
AB42 1TF
Tel: +44 (0)1779 477 210
sales@thistlemarine.co.uk
www.thistlegroup.co.uk

“service,
strength and
quality”

THISTLE GROUP



HEILA MARINE CRANE
MODEL HLRM 70-4S
SERIAL NO: H9251

CRANE ON SKID

ASSET NUMBER TM0105

HEILA

Marine Cranes

**SPECIFICATIONS
SCHEMA TECNICA**

HLRM 70-4S

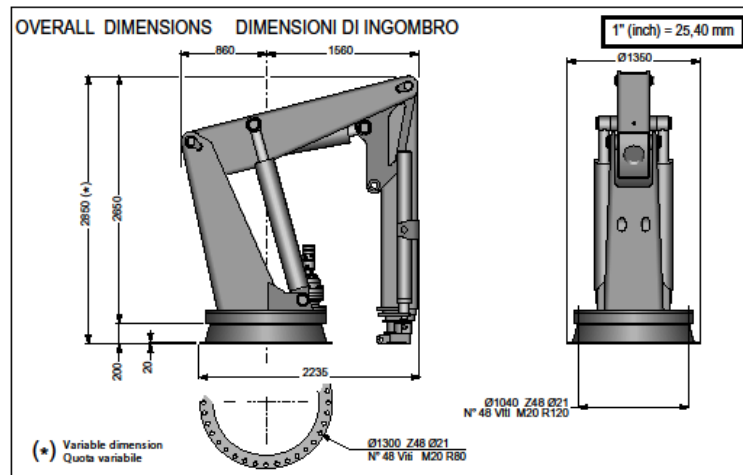

TECHNICAL DATA		DATI TECNICI	
Hydraulic extensions	Sfilii idraulici	N°	4
Max torque	Momento massimo	t-m	70
Slewing torque	Coppia di rotazione	kg-m	8500
Slewing angle (continuous)	Angolo di rotazione (continuo)	°	360
Pump capacity	Portata della pompa	l/min	65
Max working pressure	Pressione massima di esercizio	bar	250
Crane weight 'empty'	Peso gru a vuoto	kg	4570
Quantity of oil recommended	Quantità di olio consigliata	l	260
Slewing speed	Velocità di rotazione	rad/min	14
Main boom liftin time	Tempo di sollevamento 1° braccio	sec	54
Secondary boom articulation time	Tempo di articolazione 2° braccio	sec	45
Boom element extension time	Tempo di estensione sfilii braccio	sec	87

OPTIONALS A RICHIESTA	
3 ton direct pull winch rope Ø14	Verricello da 3 ton. in tiro diretto fune Ø14
Sheave block with Ø280 pulley	Bozzello con puleggia Ø280
Winch limit switch	Fine corsa verricello
Slewing limit switch (400°)	Fine corsa rotazione (400°)
Cab with windows and wipers	Cabina con vetri e tergicristalli
Electrohydraulic power pack (HP 40)	Centralina elettroidraulica (HP 40)
Off-machine distributor controls	Comandi distributore fuori macchina



THISTLE GROUP HQ

5 Baltic Place, Peterhead,
Aberdeenshire, Scotland,
AB42 1TF

Tel: +44 (0)1779 477 210
sales@thistlemarine.co.uk
www.thistlegroup.co.uk